

## **LISTE DES ANNEXES**

**ANNEXE 1** : Carte Jeppesen

**ANNEXE 2** : Transcription du CVR

**ANNEXE 3** : Courbes FDR

**ANNEXE 4** : Transcriptions ATC

**ANNEXE 5** : Service Bulletin ABSC N° Fo50-32-4, révision 1

**ANNEXE 6** : Service Lettre 137, Fokker

**ANNEXE 7** : Service Bulletin Fokker N° F50-32-035

**ANNEXE 8** : Consigne de navigabilité LUX-2002-001

**Remarque :**

**Les travaux relatifs au DFDR, au CVR et aux radiocommunications ne sont pas encore finalisés. Il pourra en résulter des modifications dans le rapport final.**

**ELLX LUXEMBOURG** **JEPPESEN LUXEMBOURG, LUXEMBOURG**  
 12 JUL 02 (11-2A) **CAT II ILS DME Rwy 24**

ATIS <b>126.3</b>		LUXEMBOURG Approach <b>118.9</b>		LUXEMBOURG Tower <b>118.1</b>	
LOC ILW <b>110.7</b>	Final Apch Crs <b>241°</b>	GS ELU NDB <b>3000'</b> (1786')	CAT II ILS RA <b>100'</b> DA(H) 1314' (100')	Apt Elev <b>1234'</b>	RWY <b>1214'</b>
<b>MISSED APCH: Climb to WLU NDB, then turn RIGHT to DIK VOR/NDB climbing to 3000'. MAX IAS 250 KT.</b>					
Alt Set: hPa Rwy Elev: 44 hPa Trans level: By ATC				Trans alt: 4500' (3286')	
Special Aircrew & Aircraft Certification Required.					MSA DIK VOR/NDB

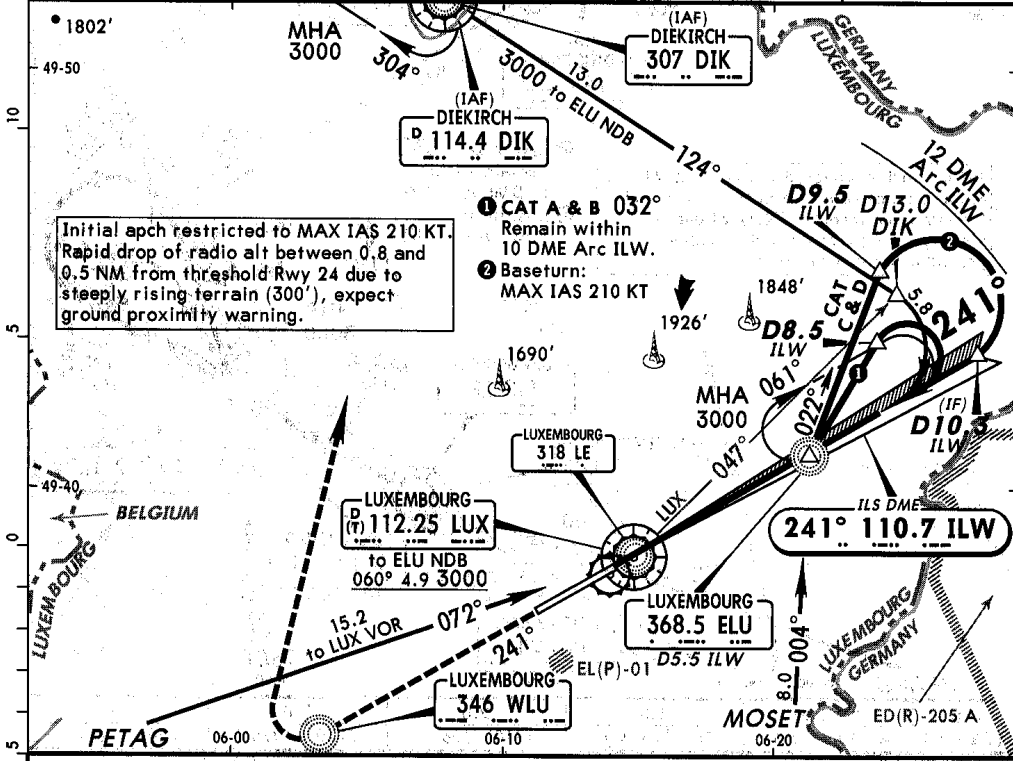
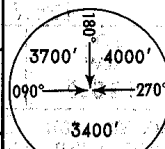

Initial apch restricted to MAX IAS 210 KT. Rapid drop of radio alt between 0.8 and 0.5 NM from threshold Rwy 24 due to steeply rising terrain (300'), expect ground proximity warning.

- 1 CAT A & B 032° Remain within 10 DME Arc ILW.
- 2 Baseturn: MAX IAS 210 KT

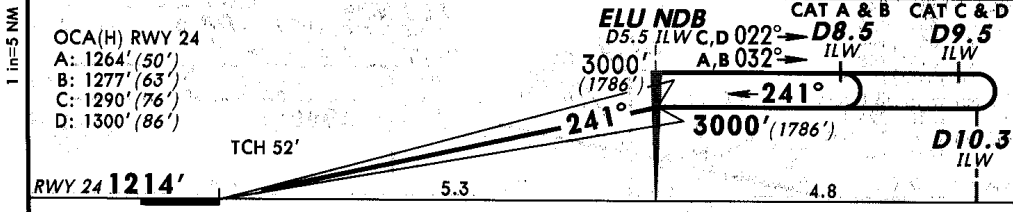

Gnd speed-Kts	70	90	100	120	140	160	HIALS PAPI PAPI	250 KT MAX	WLU 346 ↑
GS	3.00°	377	485	539	647	755			

JAR-OPS STRAIGHT-IN LANDING RWY 24  
 CAT II ILS  
 ABCD  
**RA 100'**  
 DA(H) 1314' (100')

RVR 300m

Operators applying U.S. Ops Specs: CAT III authorization required below RVR 350m.  
 CHANGES: LUX VOR frequency. © JEPPESEN SANDERSON, INC., 1999, 2002. ALL RIGHTS RESERVED.

Temps UTC	Commandant de Bord	Officier Pilote de Ligne	Contrôle	Bruits ou traduction
08 h 33 min 49				Début d'enregistrement
09 h 01 min 25			Niner six four two turn right heading two two zero to intercept cleared for approach report established on the localizer	
09 h 01 min 31		Right heading two two zero. And euh cleared approach... and we call you established on the localizer nine six four two		
09 h 01 min 42		Oh, freck, da gin mir nach virun all Mensch geholl hei		<i>Oh dis donc, alors on va nous prendre avant tout le monde</i>
09 h 01 min 43	He			
09 h 01 min 44		Mir gi nach virun jidwerengem virgeholl hei		<i>On nous prend encore avant tout un chacun</i>
09 h 01 min 58		Solle mer de seat belt umachen?		<i>Est-ce qu'on allume le seat belt?</i>
09 h 02 min 00	Yo yo dat wier villeicht net schlecht			<i>Oui oui, ça ne serait peut-être pas mauvais</i>
09 h 02 min 02	Mir müssen hei fir d'approche ehhhh			<i>On doit ici pour l'approche .....ehhhh</i>
09 h 02 min 04	100 Fouess			<i>100 pieds</i>
09 h 02 min 07		Yo, ech hun dat schon dran		<i>Oui, je l'ai déjà affiché</i>
09 h 02 min 09	Loc ass alive an captured			<i>Loc est vivant et capturé</i>
		Checked		

Temps UTC	Commandant de Bord	Officier Pilote de Ligne	Contrôle	Bruits ou traduction
09 h 02 min 12	So him, ech geng villeicht beschéd soen färer Weis dass wa mer bei Echo keng 300 meter hun, dass mer dann e goaround machen an op Dikrech fléen	Missed approach heading		<i>Je lui dirais quand même pour être honnête que si on n'a pas 300 mètres à Echo, qu'on va alors faire une remise de gaz et procéder vers Diekirch</i>
09 h 02 min 32		The Lux euh nine six four two is now established on the localizer		
09 h 02 min 37			Luxair niner six four two contact tower on one one eight decimal one, äddi	Äddi = au revoir
09 h 02 min 41		Eighteen one nine six four two , äddi		Äddi = au revoir
09 h 02 min 51		Turn, gudden Moien Luxair nine six four two is established I L S two four		<i>Tour, bonjour.....</i>
09 h 02 min 52				Bruits similaires au mouvement d'un siège
09 h 02 min 57			Luxair nine six four two gudden Moien, continue approach. The wind is calm R V R beginning two five zero meters, mid section two five zero meters,	<i>Gudden Moien = bonjour</i>
09 h 03 min 04	Oh, dat brengt neischt			<i>Oh, ça n'apporte rien</i>
09 h 03 min 07	Oh, dat brengt neischt			<i>Oh, ça n'apporte rien</i>

Temps UTC	Commandant de Bord	Officier Pilote de Ligne	Contrôle	Bruits ou traduction
09 h 03 min 08		Euh... that's copied Luxair nine six four two... but euh we need three hundred meters for the approach	stop end two two five meters	
09 h 03 min 16	So, mir gin weider fir bis ELU, wa mir dann neischt hätten, dann ehhhhhh			<i>Dis qu'on continue jusqu'à ELU, si on n'a rien , alors ehhhhh</i>
09 h 03 min 18		Yo	Nine six four two copied... euh so continue approach and I'll keep you advised we didn't have three hundred euh... euh during the last time	Oui
09 h 03 min 26	Oh			
09 h 03 min 28		Euh Roger nine six four two we keep you advised we're proceeding to ELU now and ...euh standing by nine six four two		C chord
09 h 03 min 38			Roger... and euh we have ehhh zero degrees wind	
09 h 03 min 42		Roger		
09 h 03 min 43			...schen , zero knots	
09 h 03 min 44		Roger		

Temps UTC	Commandant de Bord	Officier Pilote de Ligne	Contrôle	Bruits ou traduction
09 h 03 min 52	Hä			
09 h 04 min 09	Sou, si mer de beacon, he nach net grât En ass 5,5 DME			<i>Bon, est-on beacon, he pas tout à fait</i> <i>Il est 5,5 DME</i>
09 h 04 min 16		Da muss é mol e beacon setzen, mei Jong		<i>Alors il faut encore sélectionner un beacon, fiston</i>
09 h 04 min 18	Yo, mé ech hun jo en DME			<i>Oui, mais j'ai un DME</i>
09 h 04 min 19		Ye Ye Ye		<i>Exclamation (rire moqueur)</i>
09 h 04 min 23		Ye Ye Ye		
09 h 04 min 25	Rire			
09 h 04 min 30		ASEL		
09 h 04 min 33		Three thousand sixty top		
09 h 04 min 35	Checked			
09 h 04 min 36		Landing altitude and briefing completed, altimeters euh set		
09 h 04 min 40		Speed ninety five one oh five one oh nine Landing altitude		
09 h 04 min 43	Two seven five meters			
09 h 04 min 44		set		
09 h 04 min 46	Yo, bon mir machen en goaround, missed approach			<i>Oui, bon on fait une remise des gaz, approche manqué</i>
09 h 04 min 53		Ground idle stop off		
09 h 04 min 57			Luxair nine six four two,	

Temps UTC	Commandant de Bord	Officier Pilote de Ligne	Contrôle	Bruits ou traduction
09 h 04 min 57			R V R three hundred meters two seven five meters ... stop end two seven five meters	
09 h 04 min 58				Bruits de sélecteur similaire au déplacement du Ground Idle Stop
09 h 05 min 00				Variation de la vitesse de rotation de la turbine
05 min 00				Bruit similaire à la commande des gaz mise en position Idle
05 min 02		.....net d'uer		<i>...ne suffit pas</i>
05 min 05		Nine six four two roger so we continue		
05 min 07		Flaps?		
05 min 08	Oh mir sin ....Flaps ten		Nine six four two you're cleared to land wind one eight zero degrees .....knots	<i>Oh nous sommes... volets dix</i>
05 min 09 s 10				Bruit similaire à la manœuvre de la commande des flaps
05 min 11 s 20				Bruit similaire à l'activation des Taxi Light
05 min 11 s 80		Gear down?		
05 min 12 s 70	Ya			
05 min 13 s 60		Clear to land nine six four two		
05 min 16 s 10				Bruit similaire à la manœuvre de la commande du train suivi des bruits de la sortie du train

Temps UTC	Commandant de Bord	Officier Pilote de Ligne	Contrôle	Bruits ou traduction
05 min 16 s 60		Dât do gett zwar....		<i>Cela ça sera.....</i>
05 min 17 s 70				Augmentation de la vitesse de rotation de l'hélice
05 min 19 s 40	Wât ass dât			Bruit <i>Qu'est-ce que c'est??</i>
05 min 21 s 20				Bruit similaire à la manœuvre de la commande des flaps
05 min 21 s 60				Bruit similaire à une variation de la vitesse de rotation de l'hélice
05 min 22 s 80	Hä			
05 min 22 s 90	Oh merde			
05 min 23 s 40				Bruit similaire à un transfert électrique
05 min 23 s 70				Single Chime
05 min 26 s 20				Bruit similaire à une réduction de la vitesse de rotation de l'hélice
05 min 27 s 00				Bruit
05 min 27 s 70				Début d'alarme GPWS « Terrain »
05 min 28 s 00				Arrêt d'enregistrement (1/3 s)
05 min 28 s 30		Bo dât war awer eng lenk		<i>Ça s'était quand même une vacherie</i>
<i>Temps non valide</i>				<i>Bo = exclamation d'étonnement</i> La portion d'enregistrement de 05 min 28 s 00 jusqu'au bruit de transfert électrique à 05 min 28 s 90 est une portion d'enregistrement du début du CVR et non ré-enregistrée



Temps UTC	Commandant de Bord	Officier Pilote de Ligne	Contrôle	Bruits ou traduction
05 min 28 s 90 <i>Temps non valide</i>	Oh merde	Bruit de respiration		Bruit similaire à un transfert électrique
05 min 29 s 10 <i>Temps non valide</i>				
05 min 40 s 10				
05 min 40 s 80				
05 min 41 s 60				
05 min 41 s 90				
05 min 44 s 60			Ready for push back next, Mike Kilo Alpha one two three	Reprise de l'enregistrement La portion d'enregistrement de 05 min 40 s 10 jusqu'au bruit de transfert électrique à 05 min 40 s 80 est une portion d'enregistrement du début du CVR et non ré-enregistrée Bruit similaire à un transfert électrique  Double Chime (deux Single Chime séparés de 0.7 seconde)  Fin d'enregistrement

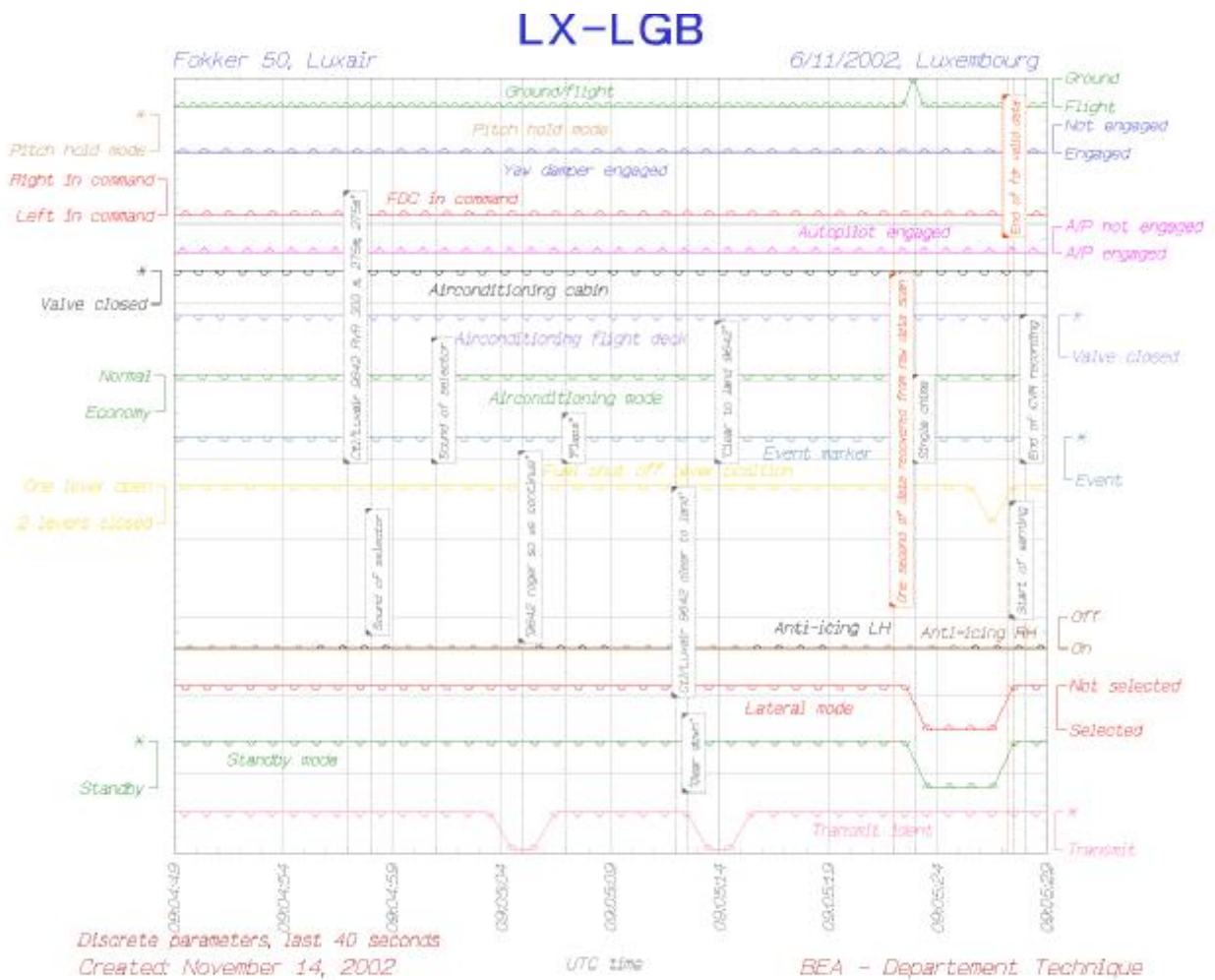

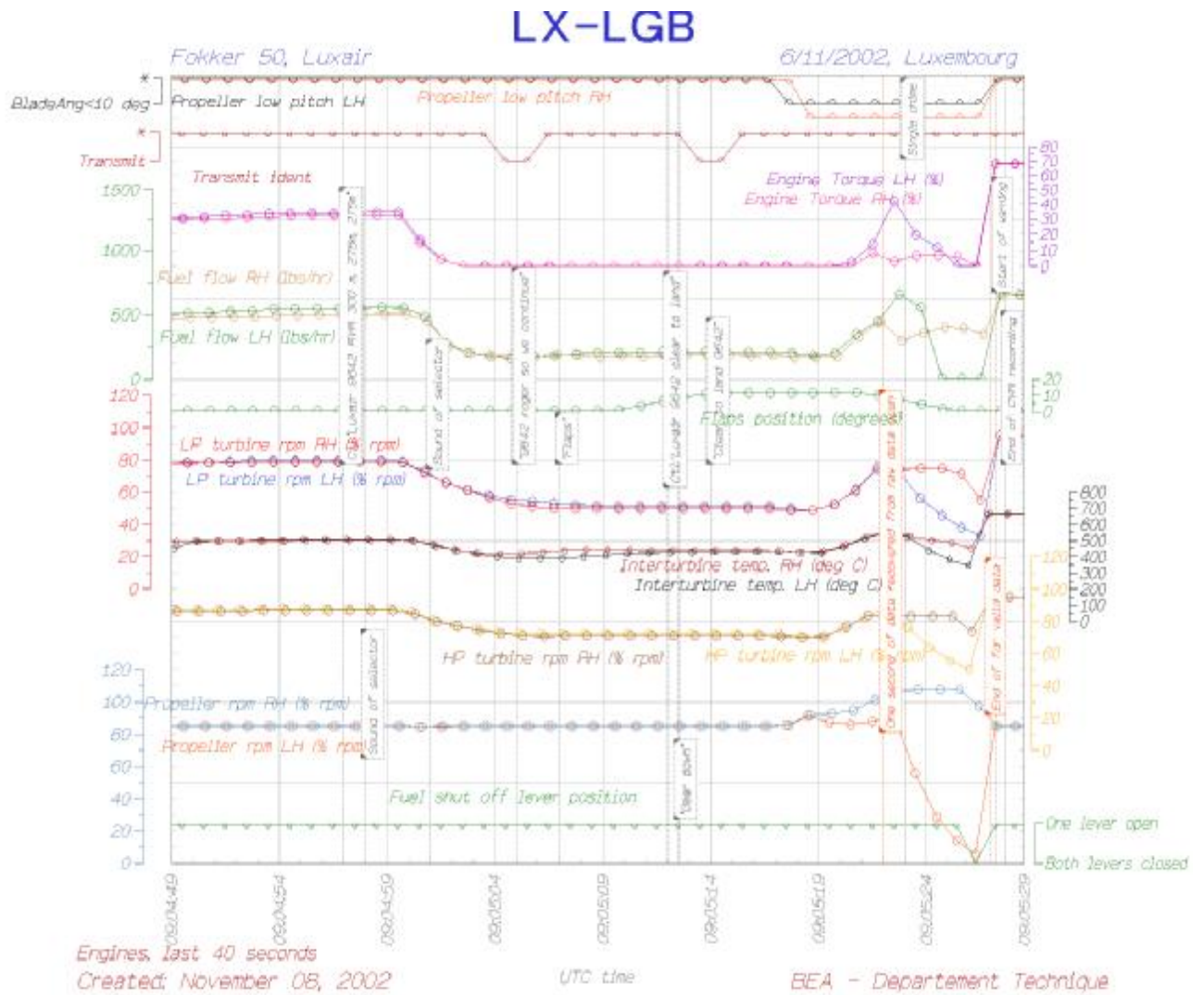

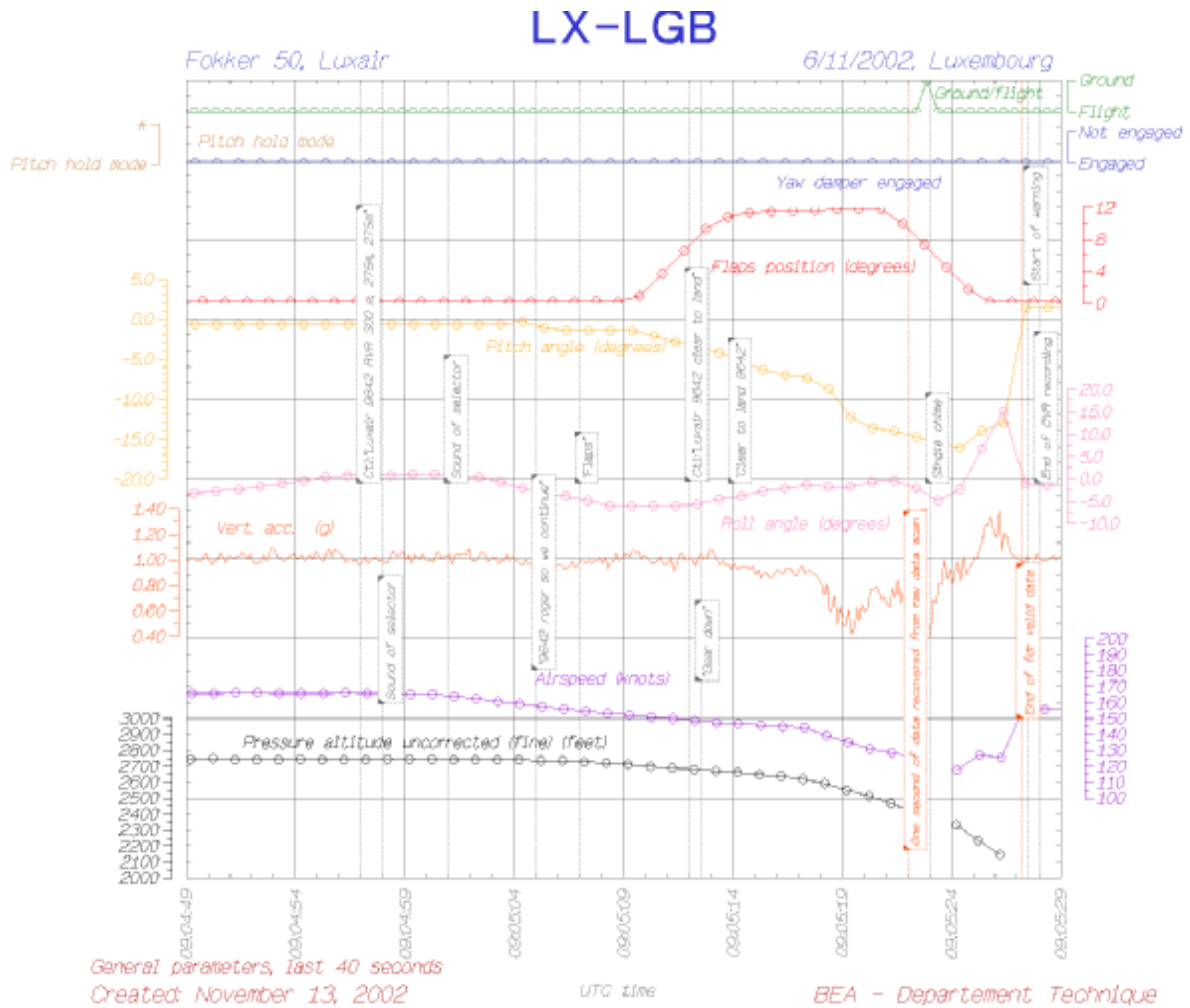

Transcript of Original Tape Recording

Subject: **Accident of LUXAIR LGL9642, Fokker 50, 6th November 2002**

**Approach radar control unit****Frequency 118.900**

Time	From	To	Communications
08:52:38	LGL9642	APP	Luxembourg Radar gudde Muergen Luxair nine six four two, descending flight level nine zero, uh, on course to..., Diekirch.
08:52:47	APP	LGL9642	Luxair niner six four two enter Diekirch holding at flight level niner zero it will be vectors later on for an I_L_S approach category two on two four. Q_N_H is one zero two tree current R_V_R beginning two five zero on mid section two seven five, stop end two two five.
08:53:05	LGL9642	APP	That's all understood, uh, Luxair nine seven, correction nine six four two.
08:53:10	LGL402	APP	Uh, Luxair four zero tree is entering Diekirch hold, passing one hundred for six zero.
08:53:15	APP	LGL402	Roger four zero two.
08:53:26	LGL9302	APP	Luxair nine tree zero two are we cleared to land?
08:53:30	APP	LGL9302	Luxair nine tree zero two is cleared for approach, for landing contact tower one one eight one, bye bye.
08:53:36	LGL9302	APP	One one eight one, Luxair nine tree four two, bye.
08:54:44	LGL9642	APP	And Luxair nine six four two is reducing speed to one sixty.
08:54:47	APP	LGL9642	Roger nine six four two.
08:56:01	LGL4452	APP	Luxair four four five two entering hold Diekirch flight level nine zero.
08:56:05	APP	LGL4452	Roger four four five two.
08:56:15	APP	SWR750	Swiss seven five zero turn left heading tree tree zero base leg.

---

08:56:20	SWR750	APP	Left heading tree tree zero base leg, Swiss seven five zero.
08:56:45	APP	SWR750	Swiss seven five zero turn left heading two seven zero to intercept the localizer, report established on the loc.
08:56:51	SWR750	APP	Left heading two seven zero to intercept the localizer, we'll report established on the loc, Swiss seven five zero.
08:57:37	SWR750	APP	Established on the loc Swiss seven five zero.
08:57:39	APP	SWR750	Roger, Swiss seven five zero continue your approach, the sensitive area is not clear yet, we have a seven four seven about to depart.
08:57:47	SWR750	APP	Okay, we continue the approach in this case, Swiss seven five zero.
08:57:56	LGL8362	APP	Luxair eight tree six two entering Diekirch holding, flight level eight zero time five seven.
08:58:01	APP	LGL8362	Roger, eight tree six two.
08:58:14	LGL4452	APP	And approach, for info, Luxair four four five two we need two hundred meters for the approach.
08:58:28	APP	LGL4452	Four four five two say again, please.
08:58:30	LGL4452	APP	Uh, just for info, we need two hundred meters for the approach.
08:58:33	APP	LGL4452	Okay no problem.
08:58:35	APP	SWR750	Swiss seven five zero is cleared for the I_L_S category tree contact tower one one eight decimal one, bye bye.
08:58:41	SWR750	APP	One one eight one and cleared for the approach cat tree, Swiss seven five zero, bye bye.
08:58:48	APP	LGL9642	Luxair niner six four two descend to tree thousand feet on one zero two tree turn left heading ...one tree zero.
08:58:57	LGL9642	APP	Descending tree thousand feet on Q_N_H, uh, one zero two tree and say again the heading?
08:59:04	APP	LGL9642	One tree zero.
08:59:07	LGL9642	APP	Uh, left heading one tree zero Luxair nine six four two.
08:59:09	CLX778	APP	Cargolux seven seven eight airborne.
08:59:11	APP	CLX778	Cargolux seven seven eight climb flight level seven zero on runway heading.
08:59:17	CLX778	APP	Runway heading, seven zero, Cargolux seven seven eight.
08:59:23	APP	LGL402	Luxair four zero two report speed.
08:59:27	LGL402	APP	Speed two ten four zero two.
08:59:29	APP	LGL402	Roger four zero two bring it back to one eight zero.

---

08:59:35	LGL402	APP	Uh, for how long, because otherwise we are burning more fuel, four zero two
08:59:39	APP	LGL402	Uh, that's just to slow you down and then I'll take you out of the hold.
08:59:42	LGL402	APP	Okay no problem, so reducing one eighty, four zero two, merci.
09:00:24	APP	LGL402	Luxair four zero two, descend to tree thousand feet one zero two tree, turn right heading zero nine zero.
09:00:30	LGL402	APP	Roger right heading zero nine zero and down to tree thousand one zero two tree, four zero two.
09:00:40	LGL8362	APP	Approach, uh, eight tree six two, could you confirm our latest R_V_R_.
09:00:46	APP	LGL8362	R_V_R beginning two seven five, mid section two seven five, stop end two two five.
09:00:52	LGL8362	APP	Okay.
09:01:09	APP	CLX778	Cargolux seven seven eight turn right heading zero six zero, climb to flight level one two zero.
09:01:17	CLX778	APP	Right heading zero six zero, climb flight level one two zero, Cargolux seven seven fi...seven seven eight.
09:01:21	APP	LGL9642	Luxair niner six four two turn right heading two two zero to intercept. Cleared for approach, report established on the localizer.
09:01:30	LGL9642	APP	Right heading two two zero and, uh, cleared approach and we call you established on the localizer nine six four two.
09:01:38	LGL5432	APP	Luxembourg approach good morning, Luxair five four tree two descending flight level one tree zero to Diekirch, information Sierra.
09:01:44	APP	LGL5432	Luxair five four tree two, uh, gudde Muergen, descend to flight level one hundred enter Diekirch holding, vectoring later on to the I_L_S_ two four, cat two.
09:01:54	LGL5432	APP	Luxair five four tree two descend flight level one hundred enter Diekirch holding for vectors runway two four, uh, how bounds, uh, how much delay do you expect?
09:02:04	APP	LGL5432	Just couple of minutes.
09:02:06	LGL5432	APP	Roger.
09:02:13	APP	CLX778	Cargolux seven seven eight climb to flight level one seven zero.
09:02:18	CLX778	APP	Cleared flight level one seven zero, Cargolux seven seven eight.
09:02:20	APP	CLX778	I have to take you on a, uh, zero six zero heading to get you on top of the Diekirch holding
09:02:27	CLX778	APP	Roger, we are turning right.
09:02:30	LGL9642	APP	Luxair nine six four two is now established on the localizer.

09:02:34	APP	LGL9642	Luxair niner six four two contact tower one one eight decimal one Äddi.
09.02.39	LGL9642	APP	Eighteen one nine six four two. Äddi

**Aerodrome control unit**

Frequency 118.100

Time	From	To	Communications
09:02:48	LGL9642	TWR	Tuerm gudde Muergen Luxair nine six four two is, uh, established I_L_S two four
09:02:54	TWR	LGL9642	Luxair nine six four two gudde Muergen, continue approach the wind is calm R_V_R beginning two five zero meters mid section two five zero meters stop end two two five meters.
09:03:07	LGL9642	TWR	Uh, that's copied Luxair nine six four two, but we need tree hundred meters for the approach.
09:03:16	TWR	LGL9642	Nine six four two copied, uh, so continue approach I keep you advised. We didn't have tree hundred, uh, during the last, uh, time.
09:03:25	LGL9642	TWR	Uh, roger nine six four two we keep you advised. We're proceeding to Elu now and, uh, standing by, nine six four two.
09:03:35	TWR	LGL9642	Roger and we have, uh, zero degrees wind, uh.
09.03.40	TWR	LGL9642	Correction zero knots.
09:03:43	LGL9642	TWR	Roger.
09:03:45	TWR	SWR750	Seven five zero report entering parking number one please.
09:03:53	TWR	SWR750	Swiss seven five zero report entering the apron.
09:03:57	SWR750	TWR	We report entering the apron, Swiss seven five zero.
09:04:10	MKA123	TWR	Tower, good morning Mike Kilo Alpha one two tree, stand two with Romeo requesting start up please.
09:04:18	TWR	MKA123	Mike Kilo Alpha one two tree good morning, start up is approved, runway in use two four, Q_N_H one zero two tree, confirm you are parking number seven.
09:04:26	MKA123	TWR	Negative, Sir, parking two and we are cleared for start one zero two tree and could you just give us the position of that lowest value of R_V_R, please.
09:04:38	TWR	MKA123	We have now on the tree positions two seven five meters.
09:04:41	MKA123	TWR	Thank you.
09:04:48	SWR750	TWR	Uh, We are entering the apron behind marshaller (garbled transmission).



---

09:04:59	TWR	LGL9642	Luxair nine six four two R_V_R tree hundred meters two seven five meters stop-end two seven five meters.
09:05:03	LGL9642	TWR	Nine six four two roger, so we continue.
09:05:07	TWR	LGL9642	Nine six four two you are cleared to land, wind one eight zero degrees five knots.
09:05:11	LGL9642	TWR	Cleared to land, uh, nine six four two
09:05:16	TWR	MKA123	Mike Kilo Alpha one two tree Luxembourg (garbled due to simultaneous transmission).
09:05:16	SWR750	TWR	(Unreadable) ... we are at the apron.
09:05:22	MKA123	TWR	Was that for Mike Kilo Alpha one two tree?
09:05:24	TWR	MKA123	That's confirmed, Mike Kilo Alpha one two tree report ready for push back.
09:05:29	MKA123	TWR	Cleared to push, thanks, one two tree.
09:05:31	TWR	MKA123	Mike Kilo Alpha one two tree, I confirm report ready for push back.
09:05:39	MKA123	TWR	Ready for push back next, Mike Kilo Alpha one two tree.
09:05:42	TWR	MKA123	Roger.
09:06:57	TWR	LGL9642	Nine six four two Luxembourg.
09:07:08	TWR	LGL9642	Luxair nine six four two Luxembourg.
09:07:30	TWR	LGL9642	Luxair nine six four two Luxembourg do you read?
09:07:55	TWR	LGL9642	Luxair nine six four two Luxembourg do you read?
09:08:10	TWR	LGL9642	Luxair nine six four two Luxembourg.
09:08:39	TWR	LGL9642	Luxair nine six four two Luxembourg do you read?

The signers certify the completeness and correctness of the present transcript  
Luxembourg Airport 13 November 2002

(s)  
Head of Air Traffic Control  
Luxembourg

(s)  
Deputy head of Air Traffic Control  
Luxembourg

**AIRCRAFT BRAKING SYSTEMS**  
Corporation

## SERVICE BULLETIN

TO: HOLDERS OF SERVICE BULLETIN F50-32-4 FOR LANDING GEAR SKID CONTROL SYSTEM - CONTROL UNIT REWORK INSTRUCTIONS

Attached to this transmittal letter is Revision No. 1 of Service Bulletin F50-32-4 (basic issue dated Aug 1/92).

### **HIGHLIGHTS OF REVISION NO. 1 DATED 29 JUNE 1994**

REVISION NO. 1 CONTAINS ALL PAGES OF THE SERVICE BULLETIN. Pages which have been revised are outlined below, together with the Highlights of the revision.

1. SECTION I, Page 1 of 6:
  - A. Added Revision No. 1 and date.
  - B. Removed reference to autobrake which was incorrect and added correct statement in the Reason paragraph (paragraph B).
  - C. Removed blank page.
2. Replace Service Bulletin F50-32-4, pages 1 thru 7 with Service Bulletin F50-32-4, Revision No. 1, pages 1 thru 6, revised Jun 29/94.

Jun 29/94

F50-32-4  
Page 1 of 1

AIRCRAFT BRAKING SYSTEMS**SERVICE BULLETIN**

**SUBJECT:** LANDING GEAR SKID CONTROL SYSTEM - CONTROL UNIT REWORK INSTRUCTIONS

SECTION I - PLANNING INFORMATION

- A. **EFFECTIVITY:** This Service Bulletin is applicable to all Control Unit Assemblies 6004125 used on F27 Mk050 (FOKKER 50) aircraft.
- B. **REASON:** This Service Bulletin is issued to inform operators of the new Control Unit 6004125-1 and provides instructions to modify the 6004125 control unit assembly into the 6004125-1 assembly. The new unit differs from the old only in the addition of one capacitor and one diode, one each per wheel board. These components prevent a condition during power up of the skid control box whereby a signal pulse is inadvertently sent to the ground control relay thus affecting the flight idle stop solenoids.
- The modification does not eliminate any existing test functions. It does not affect the antiskid control functions.
- C. **DESCRIPTION:** The Service Bulletin provides rework instructions for:
- (1) Addition of one capacitor (C76) and one diode (CR10) on each wheel control board.
  - (2) Reidentifying reworked boards and control unit and performing testing at unit bench and aircraft levels.
- D. **COMPLIANCE:** Compliance with this Service Bulletin is to be accomplished at the option and expense of the operator. It is recommended this rework be accomplished when the control unit is removed or being repaired for another reason.
- E. **APPROVAL:** Compliance with this Service Bulletin does not alter FAA TSO conformance.
- F. **MANPOWER:** Eight man-hours (estimated) are required to modify, reidentify and test one control unit. This includes six hours allotted for minimum testing. This estimate does not include the time required to remove, install and test the unit in the aircraft.
- G. **MATERIAL - COST AND AVAILABILITY:** Obtain capacitor and diode locally from best source as required.
- H. **TOOLING:** None.
- I. **WEIGHT AND BALANCE:** None.
- J. **ELECTRICAL LOAD DATA:** Not affected.
- K. **REFERENCE:** AP-647 (32-47-56) Component Maintenance Manual for Skid Control Unit Assembly 6004125 (basic issue dated 14 February 1986), Revision No. 2 dated 21 March 1989.
- L. **OTHER PUBLICATIONS AFFECTED:** None.

Aug 1/92  
Revision No. 1  
Jun 29/94

Fo50-32-4  
Page 1 of 6

**AIRCRAFT BRAKING SYSTEMS**  
CorporationSECTION II - ACCOMPLISHMENT INSTRUCTIONS

The following instructions detail the steps required to rework the Control Unit Assembly 6004125 to 6004125-1.

**CAUTION:** PRINTED WIRING BOARDS CONTAIN DEVICES SUSCEPTIBLE TO DAMAGE OR DEGRADATION FROM ELECTROSTATIC DISCHARGE (ESD). HANDLING PRECAUTIONS AND REPAIR PROCEDURES APPLICABLE TO ELECTROSTATIC SENSITIVE DEVICES (ESSD) ARE REQUIRED.

A. Removal of Both Wheel Control Boards

- (1) Release turnlock fastener at the rear of the control unit.
- (2) Remove screw from the top of the control unit assembly and slide chassis subassembly free of cover. Retain the screw and cover until reassembly.

**NOTE:** Note location of subassembly serial number relative to "Inboard/Outboard" card slot location.

B. Rework of Wheel Control Boards

**CAUTION:** POLYURETHANE COATINGS MUST BE THOROUGHLY REMOVED FROM THE AREAS TO BE RESOLDERED OR AN INADEQUATE ELECTRICAL CONTACT WILL RESULT. POSITION COMPONENTS CAREFULLY TO ASSURE ADEQUATE CLEARANCE OF COMPONENT BODIES AND LEADS WITH REGARD TO ADJACENT COMPONENTS.

**NOTE:** For removal and application of urethane coatings, see Replacing Components on Circuit Boards paragraph in referenced Component Maintenance Manual.

- (1) Rework Control Board Subassembly 6004125 into 6004125-1 as follows (See Figure 1):
  - (a) Install Capacitor M39014/02-1411 (C76) and Diode JANTXIN4148-1 (CR10) on the non-component side of board as shown in Figure 1.

**NOTE:** Use Insulation Sleeving B7444-3-2-16B and Hysol 0151 Sealant as required.

- 1 Solder each component to board and trim ends.
- 2 When installing a new component, maintain 0.03 inch (0,76 mm) minimum space between the component and the surface of the board.

**CAUTION:** AVOID CONTAMINATION OF THE BOARD CONNECTOR PINS WITH RESIDUE FROM THE CLEANING AND COATING PROCESSES.

- 3 Clean components and reworked area with Freon TP-35 and allow to dry thoroughly.

Aug 1/92  
Revision No. 1  
Jun 29/94

Fo50-32-4  
Page 2 of 6

**AIRCRAFT BRAKING SYSTEMS**  
Corporation

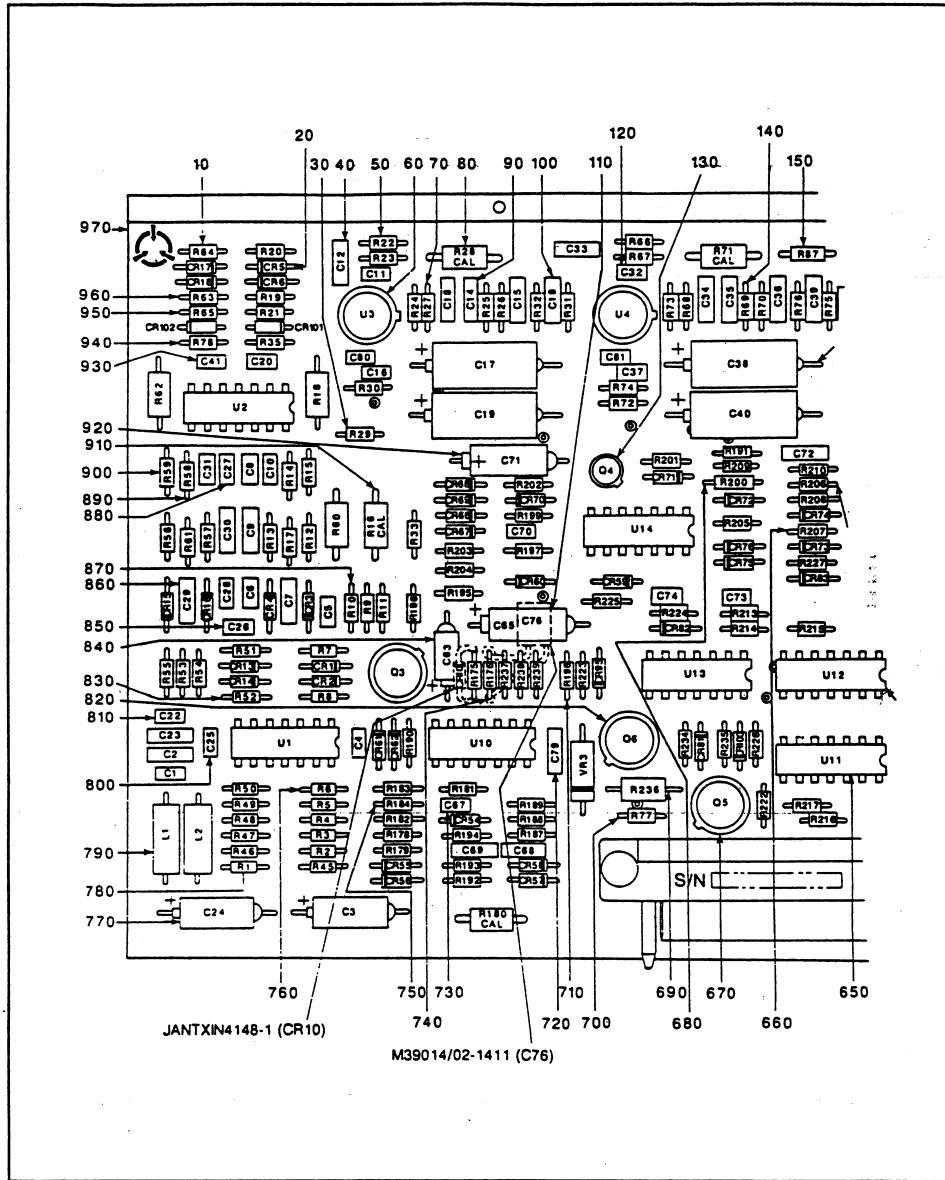

Modification of Wheel Control Board to 6004384-2/5R90-829  
Figure 1 (Sheet 1 of 2)

Aug 1/92  
Revision No. 1  
Jun 29/94

Fo50-32-4  
Page 3 of 6

**AIRCRAFT BRAKING SYSTEMS**  
CORPORATION

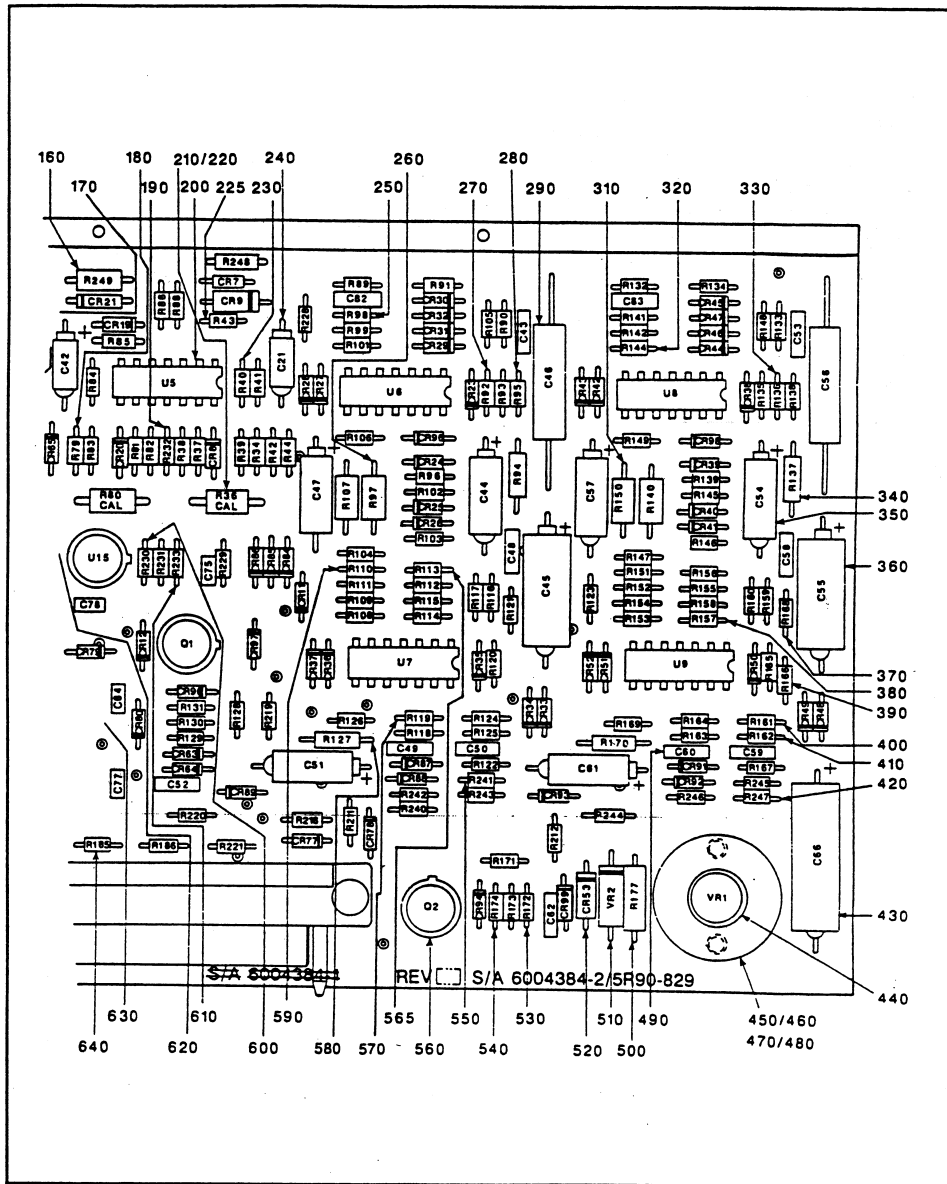

Modification of Wheel Control Board to 6004384-2/5R90-829  
Figure 1 (Sheet 2 of 2)

Aug 1/92  
Revision No. 1  
Jun 29/94

Fo50-32-4  
Page 4 of 6

**AIRCRAFT BRAKING SYSTEMS**  
Corporation

**WARNING:** USE POLYURETHANE COATING ONLY IN A WELL-VENTILATED AREA. DO NOT INHALE FUMES AND AVOID PHYSICAL CONTACT WITH THE COATING.

- 4 Apply a protective coating of Hysol PC-29M or Humiseal 1B31 over each component and the repaired area of the board. Apply only a very thin coat, 0.002 inch (0,051 mm) maximum and do not allow a buildup of coating between the other parts of the board.

C. Reidentification of Control Boards

- (1) Board identification is located adjacent to the board connector as shown in Figure 1.
- (2) On each control board, cross out but do not obliterate existing identification.
- (3) Reidentify board as part number S/A 6004384-2/5R90-829 in 0.10 inch (2,54 mm) high characters, using a contrasting color epoxy marking ink, Hysol Wornowink, Series M.

D. Reidentification of Control Unit Assembly 6004125 to 6004125-1

- (1) Remove existing Identification Plate 6004357 from control unit and discard.
- (2) Using a new Identification Plate 6004357, metal stamp existing control unit serial number on designated pad and "-1" after part number 6004125 in 0.06 inch (1,52 mm) high characters.
- (3) Install new Identification Plate 6004357 on the control unit.

E. Control Unit Reassembly

- (1) Install each "S/A 6004384-2/5R90-829" Wheel Control Board Subassembly in appropriate card slot.
- (2) Slide chassis subassembly into the cover using retained screw. Secure turnlock fastener at rear of control unit.

F. Acceptance Testing of Control Unit Assembly 6004125-1

- (1) Perform full control unit assembly test in accordance with TESTING AND FAULT ISOLATION section of referenced Component Maintenance Manual, paragraph 3.

G. On-Board Aircraft BITE Test of Control Unit

- (1) An aircraft checkout (BITE test) of the control unit should also be performed with Auto-Brake powered down.

Aug 1/92

Fo50-32-4  
Page 5 of 6

**AIRCRAFT BRAKING SYSTEMS**  
Corporation

SECTION III – MATERIAL INFORMATION

- A. The following parts are required to rework each brake assembly.

New Part Number	Units Per Assembly	Nomenclature	Old Part Number	Disposition
M39014/02-1411	1	CAPACITOR	-	-
JANTXIN4148-1	1	DIODE	-	-
6004357	1	PLATE, Identification ....	6004357	Discard

- B. The following bulk material shall be required.

Bulk Material – As Required	Recommended Source
Cleaning Solvent TP-35 Freon	E.I. DuPont DeNemours & Company, Incorporated Petrochemicals Department Freon Products Division 1007 Market Street Wilmington, DE 19898
Insulation Tubing B7444-3-2-16B	Commercially available
Sealant 0151	Hysol Division The Dexter Corporation 211 Franklin Street Olean, NY 14760
Sealant, Polyurethane Coating Type PC-29M	Hysol Division The Dexter Corporation 1505 East Don Julian Road P.O. Box 1282 Industry, CA 91749-1282
Humiseal Electronic Component Protective Coating IB31	Columbia Chase Corporation Humiseal Division 26-60 Brooklyn-Queens Expressway West P.O. Box 445 Woodside, NY 11377-0445
Trichloroethane Specification MIL-T-81533	Commercially available
Stiff-Bristled Fiberglass Brush	Commercially available
Epoxy Marking Ink Hysol Wornowink Series M Specification MIL-I-43553	Hysol Division The Dexter Corporation 1505 East Don Julian Road P.O. Box 1282 Industry, CA 91749-1282

Aug 1/92  
Revision No. 1  
Jun 29/94

Fo50-32-4  
Page 6 of 6





**Fokker 50**  
SERVICE LETTER

ATA ch. 76

137

ENGINE CONTROLS

Automatic Flight Idle Stop - Operation of the Flight-Idle Stop Solenoids during Flight.

Effectivity: All F27 Mark 050 and 0502 aircraft.

Introduction

A primary (mandatory) mechanical stop is installed in the flight compartment to prevent inadvertent movement of the power levers into the Ground (or Beta) range during flight. In addition to this, a secondary (back-up) stop is installed on each engine, this is the automatic flight-idle stop.

This Service Letter informs the operators about two issues related to the operation of the automatic flight-idle stop; Firstly the possibility that pilots may lift the ground-range selector-levers and move the power levers through the primary stop during flight. Secondly, the possibility of inadvertent operation during flight of the secondary or so called automatic flight-idle stop.

Background information/Recommendations

Primary stop (Refer to figure 1)

It has been reported that handling of the ground-range selector-levers occurs during flight, e.g. when the hand of the pilot holds the selector levers during turbulent weather conditions. This may result in the situation that the power levers pass the primary stop and now rest against the secondary stop. When the engine controls are incorrectly adjusted this may result in a propeller RPM/drag increase. When the power levers remain against the secondary stop during aircraft landing, it may not be possible to move the power levers into the Ground range due to the imposed friction.

AFM procedures recommend operation of the selector levers only after nose wheel touch-down. For this issue it is considered the operators responsibility to take action where considered appropriate.

Page	1	2	3	4															
Revision	-	-	-	-															

Dec 20/94

Fokker 50  
Service Letter 137  
Page 1



**Fokker 50**  
SERVICE LETTER

Secondary stop (Refer to figure 1 and 2)

The secondary or so called automatic flight-idle stop prevents inadvertent entering of the propeller into the Ground range during flight if the ground-range selector-levers are accidentally operated. The location of this secondary stop on the engine also ensures protection after a control cable failure.

When the flight-idle stop solenoids (one on each engine) are energized, the lock-lever is withdrawn from the power levers. This makes it possible to retard the power levers into the Ground range after landing of the aircraft. During normal operation of the system, the solenoids will be energized after landing when one of the following input signals is available:

- Wheel speed-up signal (20 MPH) from the anti-skid control system
- Ground signal from the Ground/Flight relays.

However in-service experience revealed that the flight-idle stop solenoids may also be energized, during flight, for a period of 16 seconds under the following circumstances:

1. When both the LH and RH main landing gear uplock-switches are de-energized at the exactly the same time. Although considered to be remote, this may happen during each flight when the landing gear is selected down.  
The occurrence of this phenomenon can be prevented with a skid control unit modification. This modification, when incorporated, changes the partnumber of the skid control unit from 6004125 into 6004125-1 and is covered by Service Bulletin Fo50-32-4 from the vendor Aircraft Braking Systems. This modification was incorporated into anti-skid unit s/n AUG92-117 and subsequent.
2. During an operational check of the anti-skid system. The AOM recommends to perform this check before the landing when a lightning strike is experienced while the landing gear is down. Besides activation of the automatic flight-idle stop, also the rating on the ERP may change automatically to Go Around when the "Cruise rating in approach" modification is incorporated (refer to SBF50-73-010) into the aircraft. Fokker considers to include a note in the AOM which informs flight crews about this possible rating change.
3. When, during flight, the TOW switch is operated from NORMAL to TOW and back to NORMAL. There is no procedure recommended in the AOM to cycle the TOW switch during flight.



**Fokker 50**  
SERVICE LETTER

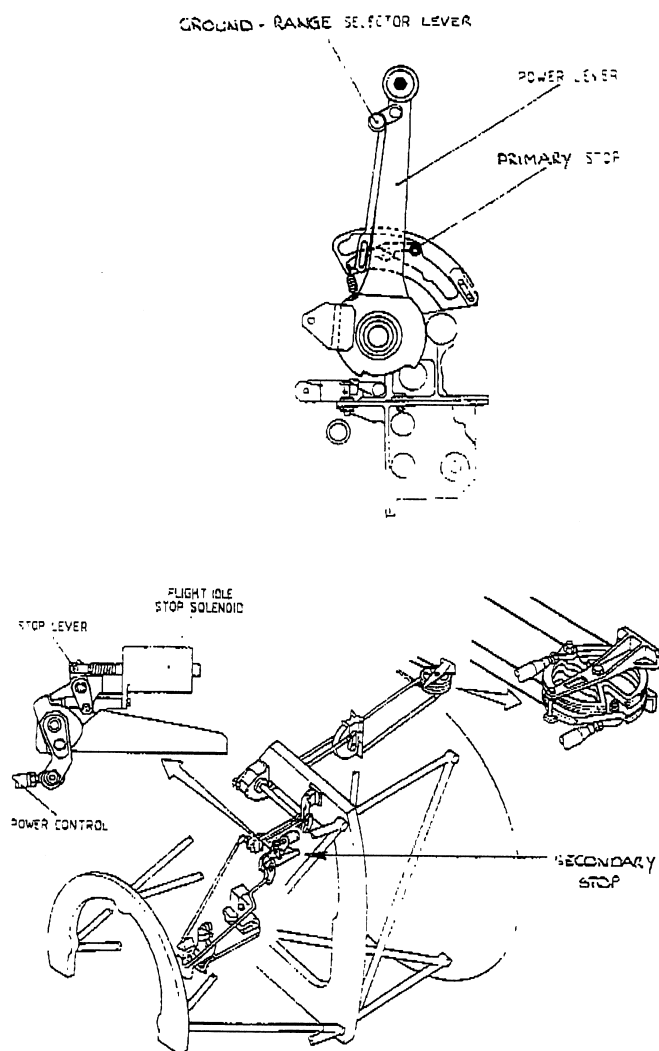

The Automatic Flight Idle Stop  
Figure 1

Dec 20/94

Fokker 50  
Service Letter 137  
Page 3



**Fokker 50**  
SERVICE LETTER

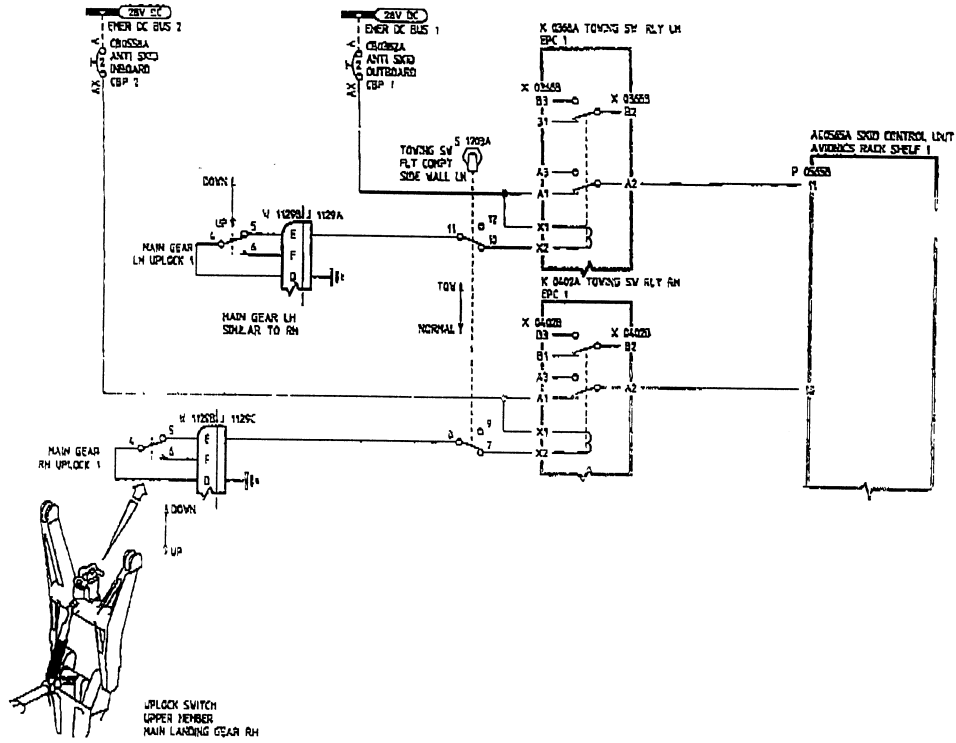

The Anti-Skid Control System  
Figure 2



LANDING GEAR

Wheels and brakes – Introduction of new ground connections for the Anti-Skid box.

1. Planning Information

A. Effectivity

- (1) F27 Mark 050, 0502 and 0604 aircraft serial numbers:  
20103 thru 20335.
- (2) Production version: Not applicable.

B. Reason

- (1) Cases have been experienced of intermittent or no braking action from the normal braking system.  
Investigation has learned that this is caused by EMI disturbance signals. The EMI signals cause undesired signals in the wiring from the wheel speed sensors to the anti skid control box, which in turn could cause undesired dump-signals from the anti-skid control box. As a result of this hydraulic brake pressure will be dumped resulting in intermittent or no braking action.

This Service Bulletin is issued to inform the operators how to change the "ground" wiring to the anti skid control box.

C. Description

- (1) This Service Bulletin tells you how to:
  - Remove the avionics shelf that holds the Anti-skid box.
  - Do rework on ground connections.
  - Install the shelf in the avionics rack.
  - Do the test procedures.

Page	1	2	3	4	5	6	7	8	9	10	11	12	13	14	15	16	17
Revision	-	-	-	-	-	-	-	-	-	-	-	-	-	-	-	-	-

Aug 02/99

SBF50-32-035  
Page 1



Service Bulletin  
Fokker 50/60

D. Compliance

- (1) Recommended.

E. Approval

- (1) The technical information contained in this Service Bulletin has been approved under the authority of the JAA Design Organization Approval no. RLD.JA.001.

F. Manpower

- (1) Approximately 8 man-hours are necessary to do this Service Bulletin on 1 aircraft.

This table of manpower will help you to schedule and do this Service Bulletin:

Instructions	Men	Man-hours	Elapsed time (hours)
Inspection	-	-	-
Removal	1	1.5	1.5
Modification	1	3	3
Installation	1	3	3
Testing	2	3	1.5
Total		8	6

- (2) The estimated hours are for direct labor done by experienced personnel. They are calculated based on the conditions given in the Service Bulletin Introduction, section 2.C., "Manpower".

G. Material - Cost and Availability

- (1) You can order the necessary parts as mod kit SBF50-32-035A, SBF50-32-035B or SBF50-32-035C.

H. Tooling - Price and Availability

- (1) Not applicable.

J. Weight and Balance

- (1) Weight change: none  
Index change: none.

K. Electrical Load Data

- (1) Not affected.

**AIRWORTHINESS DIRECTIVE****AD : LUX-2002-001**Grand-Duché de Luxembourg  
Ministère des Transports  
Direction de l'Aviation Civile  
(DAC)

**Applicability** : Fokker F.27 Mk.050 and 0502 series airplanes; certificated in any category.

**Note 1** : This AD applies to each airplane identified in the preceding applicability provision, regardless of whether it has been modified, altered, or repaired in the area subject to the requirements of this AD.

**Compliance** : Required as indicated, unless accomplished previously.  
To prevent the selection of a lower pitch than the low pitch for flight.

**Corrective actions** :

- 1.**
  - LANDING GEAR SKID CONTROL SYSTEM – Control unit rework instructions in accordance with Fokker 50 Aircraft Braking Systems Service Bulletin Fo50-32-4 revision 1 dated 29/06/1994.
  - WHEELS AND BRAKES – Introduction of new ground connections for the Anti-Skid Box in accordance with Fokker 50 Service Bulletin F50-32-035.
  - ENGINE CONTROLS – Automatic Flight Idle Stop – Operation of the Flight-Idle Stop Solenoids during Flight in accordance with Fokker 50 Service Letter N°137/1994

- 2.**

All responsible aircraft pilots have to be explicitly and expressly informed that there are certain conditions where the solenoids can be inadvertently activated in flight. The reference to the corresponding chapters in the Airplane Flight Manual (AFM) has to be noticed to the pilots.

**Effective Dates**

Corrective action 1 of this amendment becomes effective on January 1<sup>st</sup>, 2003.

Corrective action 2 of this amendment becomes effective on November 29, 2002.

Issued in Luxembourg, on November 29, 2002.

Airworthiness office. Direction of Civil Aviation